

# S-A-PB-ST201

## Turnstile

### Product Description

Delta turnstile S-A-PB-ST201 is designed for access control of entrance. The turnstile is suitable for various scenes including commercial building, residential building, school, hospital and construction site. It can verify smart card or recognize face for opening



S-A-PB-ST201

### Features

- Anti-pinch: Automatic rebound when blocked
- Anti-collision: The swing gate is locked without receiving opening signal
- Breakthrough Alert: Continuous alarm in case of break-in
- Intelligent Voice Broadcast
- Human Friendly Interface, easy to use
- Automatically reset when no person passes through for a preset time period
- Accurately remember the number of passersby
- Smart card or facial recognition



**SOLUTIONS  
EXPERT**

Features and specification are subject to change without prior notice

**ACCESS CONTROL**

# S-A-PB-ST201

Turnstile

## Specification

<b>Model</b>	<b>S-A-PB-ST201</b>
Turnstile Type	Server
Outline Dimension (mm)	1600 x 160 x 982 (mm)
Material	Body: 304 Stainless Steel Swing Gate: Acrylic / Tempered Glass
Working Environment	Indoor environment
Working Voltage	DC24V
Working Temperature	-20°C-60°C
Passageway Width	650-900mm

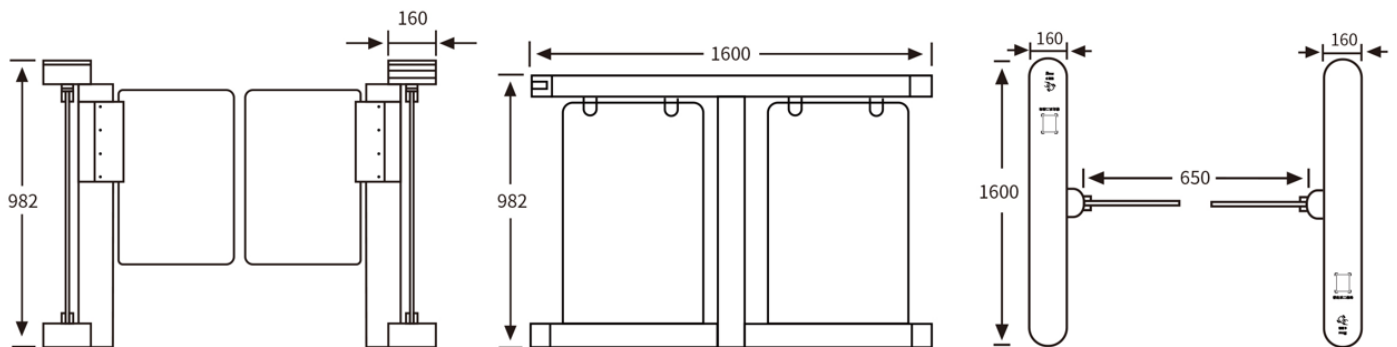

Passageway Width  $\leq 650$



Passageway Width  $\leq 900$



**SOLUTIONS  
EXPERT**

Features and specification are subject to change without prior notice

**ACCESS CONTROL**